

NSL Stainless Steel

Vertical In-line Centrifugal Pump

The DESMI NSL Stainless Steel pump meets the special marine and industrial market requirements for:

- Aggressive fluids
- Rigid design
- High efficiency
- Low NPSH values
- Easy installation/service

and further, an attractive price.



Capacity range:

30 - 1200 m³/h (132 - 5283 USGPM) at 50 Hz
30 - 1400 m³/h (132 - 6164 USGPM) at 60 Hz

Pressure range:

15 - 60 mLC at 50 Hz
15 - 80 mLC at 60 Hz

Temperature range:

With standard mech. shaft seal up to 80 °C (170 °F)
With special mech. shaft seal up to 140 °C (284 °F)

Material specification	NSL with code /S
Pump casing	Super Duplex SAF 2507
Impeller	Super Duplex SAF 2507
Wear ring	Super Duplex SAF 2507
Shaft seal cover	Super Duplex SAF 2507
Shaft	Super Duplex SAF 2507
Shaft seal	Mechanical

Design Features

The pump is a vertical in-line, radially split, single-stage centrifugal pump with connecting flanges according to international standards. The pump is designed for mounting with electric motors having different international flange dimensions.

The pump casing is equipped with a replaceable sealing ring.

The impeller is made with double-curved blades to ensure low NPSH-values and high efficiency.

The bearing unit is equipped with sturdy ball bearings and the small types are fitted with lifetime-lubricated bearings. In the larger types the lower bearing is a double bearing for which a lubrication point is provided.

A shaft in stainless steel with mechanical shaft seal of an approved brand is standard.

Applications

Within the marine and industry area the NSL pumps in Super Duplex stainless steel is by far the best choice for use in applications where the pumped liquids are aggressive and/or polluted.

Some of the possible applications are mentioned below - many other applications can be found for these pumps within the industry and marine area.

- Scrubber recirculation (Exhaust gas cleaning)
- Chemical feed or transfer
- Pharmaceutical
- Fresh and seawater cooling
- Oil and gas/offshore
- Water treatment systems

All pump sizes are available as self-priming pumps by means of a separate built-on air-operated ejector priming unit, or built-on priming pump

Ask for brochures on the DESMI ejector in Super Duplex, if you need further information about this - or find it on our website.

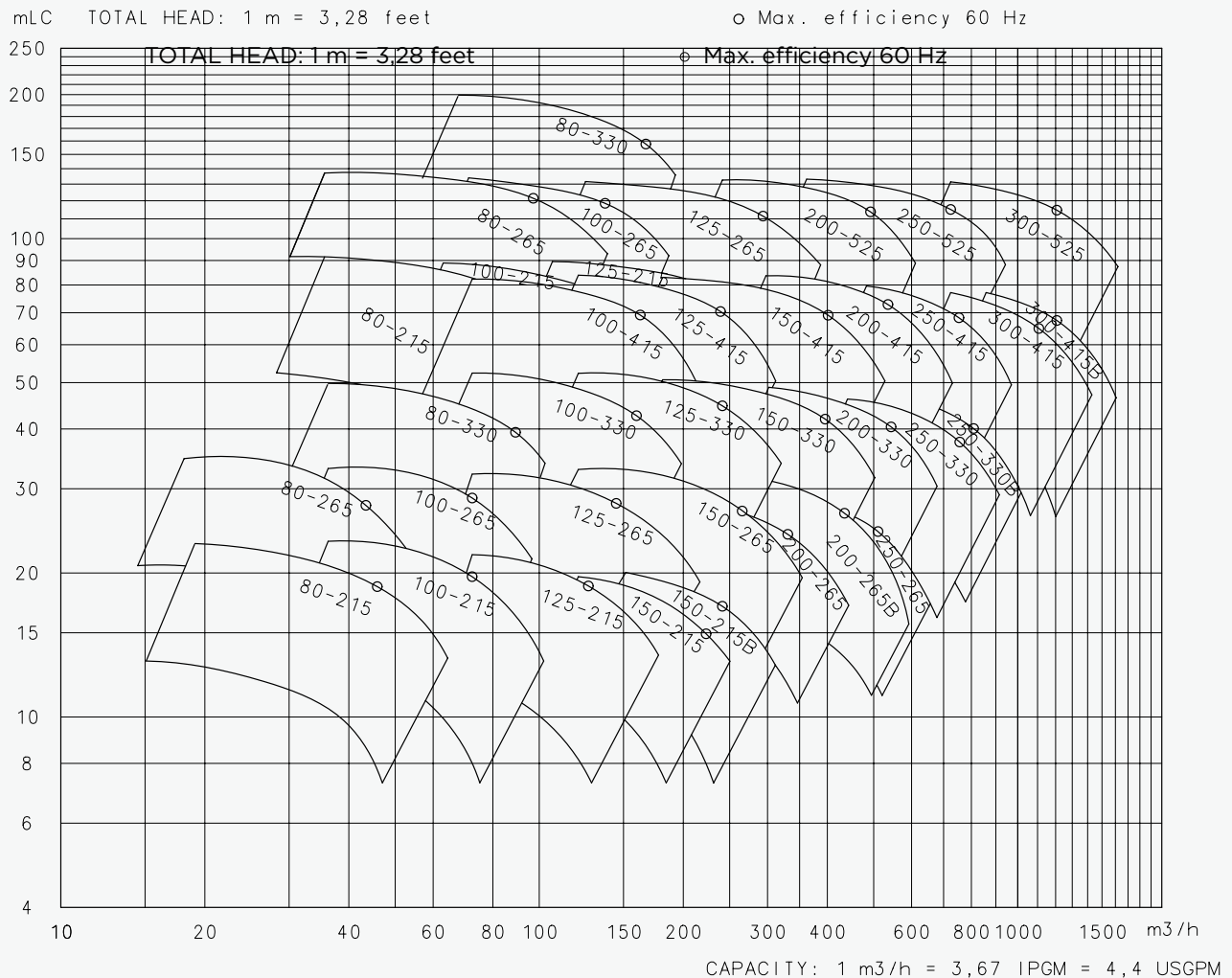

Design Details

Pumps With \varnothing 215 And \varnothing 265 Impeller
Suction and discharge flange dimensions are identical. The line through inlet and outlet is flush with the center line of the shaft. The pumps are mounted with one impeller wear ring.

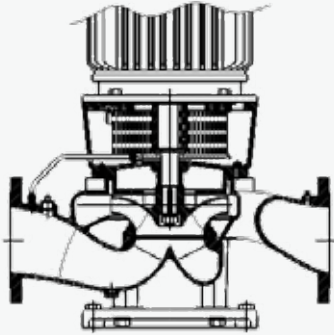

Pumps With \varnothing 330, \varnothing 415 and \varnothing 525 Impeller
Dimension of the suction flange is one size larger than that of the discharge flange. The line through inlet and outlet is tangential offset in relation to the center line of the shaft. The pumps have two impeller wear rings.

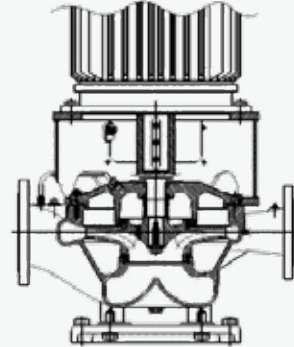

Monobloc Without Bearing

The pump is for small capacities and limited space. This version has no pump bearings, only the ball bearings in the standard electric motor. The power transmission is by rigid coupling. Dismantling of the pump parts is possible without removing the pump casing from the piping.

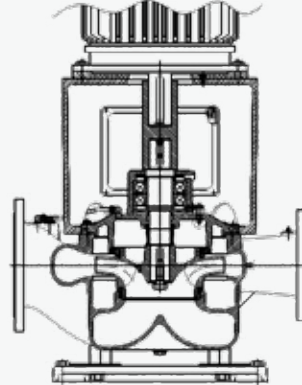
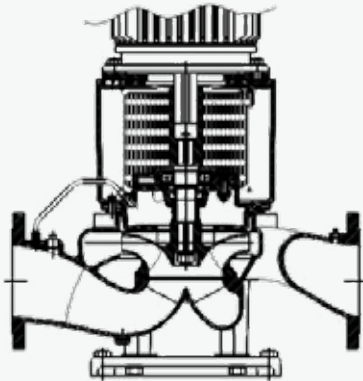

Monobloc With Bearing

The pump is for major capacities and heavy loads, especially recommended where the advantage of the spacer coupling is of no importance and where a small overall height is required.

The pump is equipped with a separate rear cover with a ball bearing and a separate motor bracket. Dismantling of the rotating pump parts is possible without removing the pump casing from the piping.

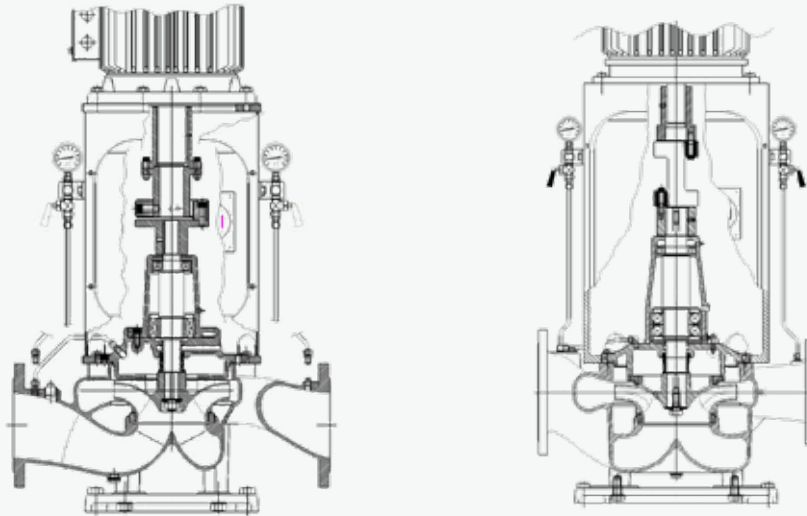

Spacer

The pump is for high capacities, heavy loads, and high pump speeds. As a special feature the pump is equipped with a spacer coupling which is a combined distance and flexible coupling. This makes it possible to remove the complete bearing housing with shaft, bearings, shaft seal, and impeller without dismantling or loosening the motor or piping. For high capacities and the resulting larger and heavier electric motors we recommend this pump version because of the easy dismantling of the rotating pump parts in connection with inspection and repair. This special feature is often a requirement within the marine industry where installations must be easy to service.